



小型铝电解电容器

MINIATURE ALUMINUM ELECTROLYTIC CAPACITORS

BXW

BXW 系列
SERIES

UPGRADE

105°C 长寿命 (10000~12000小时) 超小型化品
105°C Long Life (10000~12000 hours), Ultra Miniaturized

◆ 特 长 / FEATURES

- 105°C、10000~12000小时品。(−40°C对应)
Load Life : 105°C 10000~12000 hours. (Temperature Range: -40°C ~ +105°C)
- 将以往的TXW系列小型化。
Smaller size than TXW series.
- RoHS指令对应品。
RoHS compliance.

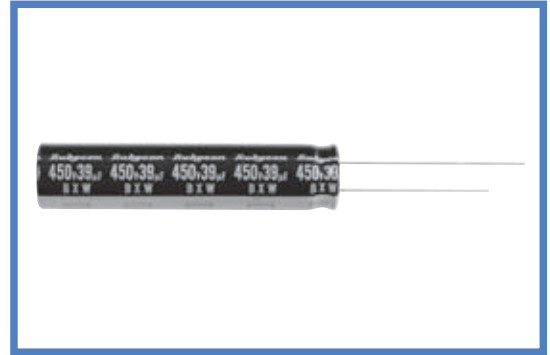

◆ 规格表 / SPECIFICATIONS

项 目 Items	特 性 Characteristics														
工作温度范围 Category Temperature Range	−40~+105°C														
额定电压范围 Rated Voltage Range	160~450V.DC														
静电容量允许差 Capacitance Tolerance	±20% (20°C, 120Hz)														
漏 电 流 Leakage Current(MAX)	$I=3\sqrt{CV}$ (施加额定电压5分钟后) $I=3\sqrt{CV}$ (After 5 minutes application of rated voltage) I=漏电流 (μA) Leakage Current C=静电容量 (μF) Capacitance V=额定电压 (V) Rated Voltage														
损失角正切值(tan δ) Dissipation Factor(MAX)	<table border="1"> <tr> <td>额定电压 (V) Rated Voltage</td> <td>160~400</td> <td>420, 450</td> </tr> <tr> <td>tan δ</td> <td>0.20</td> <td>0.25</td> </tr> </table>	额定电压 (V) Rated Voltage	160~400	420, 450	tan δ	0.20	0.25	(20°C, 120Hz)							
额定电压 (V) Rated Voltage	160~400	420, 450													
tan δ	0.20	0.25													
耐 久 性 Endurance	105°C 环境中，不超过额定电压的范围内叠加额定纹波电流，连续加载右表时间后，满足以下各项要求。 After life test with rated ripple current at conditions stated in the table below at 105°C, the capacitors shall meet the following requirements.														
	<table border="1"> <tr> <td>静电容量变化率 Capacitance Change</td> <td>初期值的±20%以内 Within ±20% of the initial value.</td> </tr> <tr> <td>损失角正切值 Dissipation Factor</td> <td>规格值的200%以下 Not more than 200% of the specified value.</td> </tr> <tr> <td>漏 电 流 Leakage Current</td> <td>规格值以下 Not more than the specified value.</td> </tr> </table>	静电容量变化率 Capacitance Change	初期值的±20%以内 Within ±20% of the initial value.	损失角正切值 Dissipation Factor	规格值的200%以下 Not more than 200% of the specified value.	漏 电 流 Leakage Current	规格值以下 Not more than the specified value.	<table border="1"> <tr> <td>铝壳尺寸 Case Size</td> <td>时间 (hrs) Life Time</td> </tr> <tr> <td>L≤20</td> <td>10000</td> </tr> <tr> <td>L≥25</td> <td>12000</td> </tr> </table>	铝壳尺寸 Case Size	时间 (hrs) Life Time	L≤20	10000	L≥25	12000	
静电容量变化率 Capacitance Change	初期值的±20%以内 Within ±20% of the initial value.														
损失角正切值 Dissipation Factor	规格值的200%以下 Not more than 200% of the specified value.														
漏 电 流 Leakage Current	规格值以下 Not more than the specified value.														
铝壳尺寸 Case Size	时间 (hrs) Life Time														
L≤20	10000														
L≥25	12000														
低 温 特 性 Low Temperature Stability (阻抗比) Impedance Ratio (MAX)	<table border="1"> <tr> <td>额定电压 (V) Rated Voltage</td> <td>160~250</td> <td>350, 400</td> <td>420, 450</td> </tr> <tr> <td>Z(−25°C)/Z(20°C)</td> <td>3</td> <td>5</td> <td>6</td> </tr> <tr> <td>Z(−40°C)/Z(20°C)</td> <td>6</td> <td>6</td> <td>10</td> </tr> </table>	额定电压 (V) Rated Voltage	160~250	350, 400	420, 450	Z(−25°C)/Z(20°C)	3	5	6	Z(−40°C)/Z(20°C)	6	6	10	(120Hz)	
额定电压 (V) Rated Voltage	160~250	350, 400	420, 450												
Z(−25°C)/Z(20°C)	3	5	6												
Z(−40°C)/Z(20°C)	6	6	10												

◆ 纹波电流修正系数 / MULTIPLIER FOR RIPPLE CURRENT

频率 (Hz) Frequency	60(50)	120	500	1k	10k	100k≤
10~82μF	0.80	1.00	1.30	1.50	2.10	2.50
82~220μF	0.80	1.00	1.30	1.50	2.00	2.25
270~820μF	0.80	1.00	1.30	1.50	1.90	2.00

◆ 副记号 / OPTION

副记号	记号 Code
PET套管 PET Sleeve (−40~+105°C)	EFR※

※有关PET套管 −25~+105°C品 (EFC品)、请另外查询。
PET Sleeve -25~+105°C (EFC) is also available, please consult our sales offices.

◆ 尺寸图 / DIMENSIONS (mm)

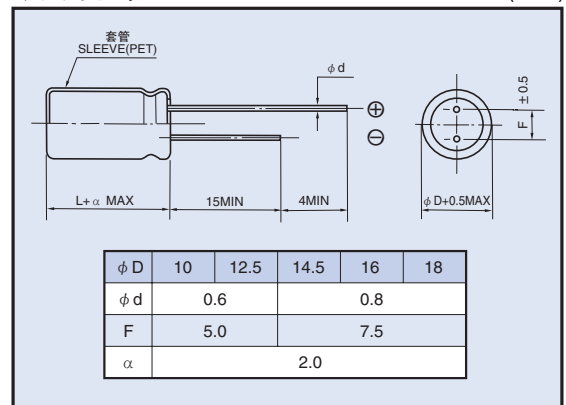

◆ 产品型号体系 / PART NUMBER

□□□	BXW	□□□□□	M	□□□	□□	D×L
额定电压 Rated Voltage	系列名称 Series	静电容量 Capacitance	静电容量允许差 Capacitance Tolerance	副记号 Option	引线加工记号 Lead Forming	铝壳尺寸 Case Size

◆标准品一览表/STANDARD SIZE

额定电压 Rated Voltage (V · DC)	静电容量 Capacitance (μF)	外形尺寸 Size φ D×L (mm)	额定纹波电流 Rated Ripple Current (A r.m.s.105°C)	
			120Hz	100kHz
160	47	10×16	0.260	0.650
	68	10×20	0.320	0.800
	82	16×16	0.540	1.350
	100	10×25	0.530	1.193
	100	12.5×20	0.600	1.350
	100	18×16	0.690	1.553
	120	10×30	0.620	1.395
	150	10×35	0.700	1.575
	150	12.5×25	0.730	1.643
	150	14.5×20	0.800	1.800
	180	10×40	0.800	1.800
	180	12.5×30	0.870	1.958
	180	16×20	0.800	1.800
	220	10×50	1.000	2.250
	220	12.5×35	1.000	2.250
	220	14.5×25	0.890	2.003
	220	18×20	0.990	2.228
	270	12.5×40	1.120	2.240
	270	14.5×30	1.100	2.200
	270	16×25	1.000	2.000
	330	12.5×45	1.240	2.480
	330	14.5×35	1.220	2.440
	330	16×30	1.200	2.400
	330	18×25	1.180	2.360
	390	14.5×40	1.380	2.760
	390	16×35	1.380	2.760
	470	14.5×45	1.520	3.040
	470	16×40	1.550	3.100
470	18×30	1.550	3.100	
560	16×45	1.760	3.520	
560	18×35	1.740	3.480	
680	18×40	2.000	4.000	
820	18×50	2.230	4.460	

额定电压 Rated Voltage (V · DC)	静电容量 Capacitance (μF)	外形尺寸 Size φ D×L (mm)	额定纹波电流 Rated Ripple Current (A r.m.s.105°C)	
			120Hz	100kHz
200	33	10×16	0.260	0.650
	47	10×20	0.320	0.800
	56	16×16	0.540	1.350
	68	10×25	0.430	1.075
	68	12.5×20	0.540	1.350
	82	10×30	0.500	1.250
	82	18×16	0.620	1.550
	100	10×35	0.640	1.440
	100	14.5×20	0.580	1.305
	120	10×40	0.740	1.665
	120	12.5×25	0.650	1.463
	120	16×20	0.800	1.800
	150	10×45	0.780	1.755
	150	12.5×30	0.800	1.800
	150	14.5×25	0.790	1.778
	180	12.5×35	0.920	2.070
	180	14.5×30	0.950	2.138
	180	16×25	0.900	2.025
	180	18×20	1.000	2.250
	220	12.5×40	1.050	2.363
	220	14.5×35	1.090	2.453
	220	16×30	1.080	2.430
	270	12.5×50	1.260	2.520
	270	14.5×40	1.260	2.520
	270	16×30	1.180	2.360
	270	18×25	1.100	2.200
	330	14.5×45	1.370	2.740
	330	16×40	1.430	2.860
	330	18×30	1.300	2.600
	390	14.5×50	1.480	2.960
	390	16×45	1.550	3.100
	390	18×35	1.430	2.860
	470	16×50	1.680	3.360
	470	18×40	1.620	3.240
560	18×45	1.770	3.540	

◆标准品一览表/STANDARD SIZE

额定电压 Rated Voltage (V · DC)	静电容量 Capacitance (μF)	外形尺寸 Size φ D × L (mm)	额定纹波电流 Rated Ripple Current (A r.m.s.105°C)	
			120Hz	100kHz
220	33	10 × 16	0.240	0.600
	47	10 × 20	0.300	0.750
	56	10 × 25	0.400	1.000
	68	12.5 × 20	0.480	1.200
	82	10 × 30	0.500	1.250
	100	10 × 35	0.640	1.440
	100	12.5 × 25	0.620	1.395
	100	14.5 × 20	0.600	1.350
	120	10 × 45	0.750	1.688
	120	12.5 × 30	0.740	1.665
	120	14.5 × 25	0.750	1.688
	120	16 × 20	0.680	1.530
	150	12.5 × 35	0.880	1.980
	150	18 × 20	0.830	1.868
	180	12.5 × 40	1.020	2.295
	180	14.5 × 30	0.910	2.048
	180	16 × 25	0.900	2.025
	220	12.5 × 45	1.050	2.363
	220	14.5 × 35	1.040	2.340
	220	16 × 30	1.030	2.318
	220	18 × 25	0.990	2.228
	270	14.5 × 45	1.300	2.600
	270	16 × 35	1.190	2.380
	270	18 × 30	1.170	2.340
	330	14.5 × 50	1.410	2.820
	330	16 × 40	1.360	2.720
330	18 × 35	1.350	2.700	
390	16 × 45	1.480	2.960	
390	18 × 40	1.550	3.100	
470	18 × 45	1.690	3.380	
560	18 × 50	1.800	3.600	

额定电压 Rated Voltage (V · DC)	静电容量 Capacitance (μF)	外形尺寸 Size φ D × L (mm)	额定纹波电流 Rated Ripple Current (A r.m.s.105°C)	
			120Hz	100kHz
250	27	10 × 16	0.260	0.650
	39	10 × 20	0.320	0.800
	47	10 × 25	0.390	0.975
	47	16 × 16	0.540	1.350
	56	12.5 × 20	0.540	1.350
	56	18 × 16	0.620	1.550
	68	10 × 30	0.500	1.250
	82	10 × 35	0.570	1.425
	82	12.5 × 25	0.570	1.425
	82	14.5 × 20	0.500	1.250
	100	10 × 45	0.720	1.620
	100	12.5 × 30	0.690	1.553
	100	16 × 20	0.800	1.800
	120	10 × 50	0.780	1.755
	120	12.5 × 35	0.790	1.778
	120	14.5 × 25	0.750	1.688
	120	18 × 20	1.000	2.250
	150	12.5 × 40	0.920	2.070
	150	14.5 × 30	0.830	1.868
	150	16 × 25	0.840	1.890
	180	12.5 × 45	0.970	2.183
	180	14.5 × 35	0.960	2.160
	180	16 × 30	0.950	2.138
	180	18 × 25	0.920	2.070
	220	14.5 × 40	1.110	2.498
	220	16 × 35	1.100	2.475
	220	18 × 30	1.100	2.475
	270	14.5 × 50	1.300	2.600
	270	16 × 40	1.270	2.540
	270	18 × 35	1.260	2.520
	330	16 × 50	1.480	2.960
	330	18 × 40	1.450	2.900
390	18 × 45	1.590	3.180	
470	18 × 50	1.830	3.660	

◆标准品一览表/STANDARD SIZE

额定电压 Rated Voltage (V · DC)	静电容量 Capacitance (μF)	外形尺寸 Size φ D×L (mm)	额定纹波电流 Rated Ripple Current (A r.m.s.105°C)	
			120Hz	100kHz
350	18	10×16	0.160	0.400
	22	10×20	0.200	0.500
	27	16×16	0.310	0.775
	33	10×25	0.330	0.825
	33	12.5×20	0.340	0.850
	33	18×16	0.380	0.950
	39	10×30	0.390	0.975
	47	10×35	0.450	1.125
	47	12.5×25	0.450	1.125
	47	14.5×20	0.420	1.050
	56	10×40	0.520	1.300
	56	12.5×30	0.550	1.375
	56	16×20	0.480	1.200
	68	10×50	0.600	1.500
	68	12.5×35	0.610	1.525
	68	14.5×25	0.560	1.400
	82	12.5×40	0.710	1.775
	82	14.5×30	0.670	1.675
	82	16×25	0.650	1.625
	82	18×20	0.520	1.300
	100	12.5×45	0.790	1.778
	100	14.5×35	0.780	1.755
	100	16×30	0.770	1.733
	100	18×25	0.760	1.710
	120	12.5×50	0.850	1.913
	120	14.5×40	0.900	2.025
	120	16×35	0.890	2.003
150	14.5×45	0.970	2.183	
150	16×40	1.000	2.250	
150	18×30	0.900	2.025	
180	16×45	1.120	2.520	
180	18×35	1.040	2.340	
220	18×40	1.200	2.700	
270	18×50	1.400	2.800	

额定电压 Rated Voltage (V · DC)	静电容量 Capacitance (μF)	外形尺寸 Size φ D×L (mm)	额定纹波电流 Rated Ripple Current (A r.m.s.105°C)	
			120Hz	100kHz
400	12	10×16	0.160	0.400
	18	10×20	0.220	0.550
	18	16×16	0.230	0.575
	22	10×25	0.240	0.600
	27	10×25	0.290	0.725
	27	12.5×20	0.340	0.850
	27	18×16	0.380	0.950
	33	10×30	0.340	0.850
	39	10×35	0.390	0.975
	39	12.5×25	0.390	0.975
	39	14.5×20	0.360	0.900
	47	10×40	0.440	1.100
	47	12.5×30	0.455	1.138
	47	16×20	0.470	1.175
	56	10×45	0.500	1.250
	56	12.5×30	0.495	1.238
	56	12.5×35	0.525	1.313
	56	14.5×25	0.495	1.238
	56	16×20	0.480	1.200
	56	18×20	0.520	1.300
	68	12.5×35	0.570	1.425
	68	12.5×40	0.600	1.500
	68	14.5×30	0.585	1.463
	68	16×25	0.570	1.425
	68	18×20	0.530	1.325
	82	12.5×40	0.650	1.625
	82	12.5×45	0.680	1.700
	82	14.5×35	0.670	1.675
	82	16×30	0.670	1.675
	82	18×25	0.640	1.600
	100	12.5×50	0.760	1.710
	100	14.5×40	0.760	1.710
	100	14.5×45	0.785	1.766
	100	16×30	0.710	1.598
	100	16×35	0.760	1.710
	100	18×25	0.710	1.598
	120	14.5×45	0.840	1.890
	120	14.5×50	0.875	1.969
	120	16×35	0.810	1.823
	120	16×40	0.860	1.935
	120	18×30	0.840	1.890
	120	18×35	0.870	1.958
150	16×45	0.950	2.138	
150	16×50	0.995	2.239	
150	18×35	0.920	2.070	
150	18×40	0.985	2.216	
180	16×50	1.070	2.408	
180	18×40	1.040	2.340	
180	18×45	1.095	2.464	
220	18×50	1.220	2.745	

◆标准品一览表/STANDARD SIZE

额定电压 Rated Voltage (V · DC)	静电容量 Capacitance (μF)	外形尺寸 Size φ D×L (mm)	额定纹波电流 Rated Ripple Current (A r.m.s.105°C)	
			120Hz	100kHz
420	15	10×20	0.190	0.475
	18	10×25	0.230	0.575
	22	10×25	0.250	0.625
	27	10×30	0.290	0.725
	27	12.5×20	0.300	0.750
	27	12.5×25	0.340	0.850
	33	10×35	0.340	0.850
	33	12.5×25	0.350	0.875
	33	12.5×30	0.400	1.000
	33	14.5×20	0.350	0.875
	39	10×40	0.390	0.975
	39	14.5×25	0.435	1.088
	39	16×20	0.400	1.000
	47	10×45	0.440	1.100
	47	12.5×30	0.440	1.100
	47	12.5×35	0.505	1.263
	47	14.5×25	0.450	1.125
	47	16×25	0.440	1.100
	56	12.5×35	0.510	1.275
	56	12.5×40	0.570	1.425
	56	14.5×30	0.560	1.400
	56	16×25	0.510	1.275
	56	18×20	0.480	1.200
	68	12.5×45	0.600	1.500
	68	12.5×50	0.670	1.675
	68	14.5×35	0.640	1.600
	68	16×30	0.560	1.400
	68	18×25	0.615	1.538
	82	12.5×50	0.690	1.725
	82	14.5×40	0.680	1.700
	82	14.5×45	0.750	1.875
	82	16×30	0.640	1.600
	82	16×35	0.690	1.725
	82	18×25	0.640	1.600
	82	18×30	0.730	1.825
	100	14.5×45	0.790	1.778
	100	14.5×50	0.845	1.901
	100	16×35	0.730	1.643
	100	16×40	0.800	1.800
	100	18×30	0.780	1.755
	100	18×35	0.835	1.879
	120	16×40	0.840	1.890
120	16×45	0.920	2.070	
120	18×35	0.850	1.913	
120	18×40	0.930	2.093	
150	16×50	0.940	2.115	
150	18×40	1.000	2.250	
150	18×45	1.060	2.385	
180	18×45	1.100	2.475	

额定电压 Rated Voltage (V · DC)	静电容量 Capacitance (μF)	外形尺寸 Size φ D×L (mm)	额定纹波电流 Rated Ripple Current (A r.m.s.105°C)	
			120Hz	100kHz
450	10	10×16	0.130	0.325
	15	10×20	0.190	0.475
	15	16×16	0.210	0.525
	18	10×25	0.230	0.575
	22	10×30	0.270	0.675
	22	12.5×20	0.280	0.700
	22	18×16	0.340	0.850
	27	10×35	0.320	0.800
	27	12.5×25	0.340	0.850
	27	14.5×20	0.335	0.838
	33	10×40	0.360	0.900
	33	12.5×25	0.360	0.900
	33	12.5×30	0.400	1.000
	33	14.5×25	0.400	1.000
	39	10×45	0.410	1.025
	39	12.5×30	0.430	1.075
	39	12.5×35	0.460	1.150
	39	14.5×25	0.430	1.075
	39	16×20	0.400	1.000
	47	12.5×35	0.480	1.200
	47	12.5×40	0.525	1.313
	47	14.5×30	0.515	1.288
	47	16×25	0.500	1.250
	47	18×20	0.460	1.150
	56	12.5×40	0.540	1.350
	56	12.5×45	0.590	1.475
	56	14.5×30	0.540	1.350
	56	14.5×35	0.580	1.450
	56	16×25	0.530	1.325
	56	16×30	0.585	1.463
	56	18×25	0.560	1.400
	68	12.5×45	0.610	1.525
	68	12.5×50	0.670	1.675
	68	14.5×35	0.620	1.550
	68	14.5×40	0.660	1.650
	68	16×30	0.610	1.525
	68	16×35	0.660	1.650
	68	18×25	0.610	1.525
	82	14.5×40	0.670	1.675
	82	14.5×45	0.740	1.850
	82	16×35	0.690	1.725
	82	16×40	0.750	1.875
82	18×30	0.730	1.825	
100	14.5×50	0.810	1.823	
100	16×40	0.770	1.733	
100	16×45	0.840	1.890	
100	18×30	0.750	1.688	
100	18×35	0.835	1.879	
120	16×45	0.880	1.980	
120	18×35	0.860	1.935	
120	18×40	0.930	2.093	
150	18×45	1.000	2.250	
150	18×50	1.060	2.385	
180	18×50	1.100	2.475	